

# Windows-Based Bandwidth Allocation on Optical Networks

ARASH HABIBI LASHKARI<sup>+</sup>, SHAHRAM JAZAYERI, DARYOUSH NAGHNEH  
ABBASPOUR

FCSIT, University of Malaya (UM) Kuala Lumpur, Malaysia

**Abstract.** A detailed understanding of the many facets of the Internet's topological structure is critical for evaluating the performance of networking protocols, for assessing the effectiveness of proposed techniques to protect the network from nefarious intrusions and attacks, or for developing improved designs for resource provisioning. In this way Available bandwidth estimation is a vital component of admission control for quality-of-service (QoS) on Internet in the world. In coming years, Optical networks are come to dominate the access network space. Ethernet passive optical networks, which influence the all of subscriber locations of Ethernet, seems bound for success in the optical access network. In our previous paper we explain about static bandwidth allocation methods weaknesses and improvements. Now, in this paper related to our totally categorize of bandwidth allocation methods to three groups as Static, Router-Based and Windows-Based, we will explain seven major weaknesses on Windows-Based dynamic group and describe the improvements on them one by one. Finally in this survey, we found some roles and principles in Router-Based dynamic bandwidth allocation methods which explain them separately. We hope in the next article we will make a comparison table among static and dynamic bandwidth allocations algorithms and propose an algorithm on dynamic bandwidth allocation and evaluate our proposed algorithm.

**Keywords:** Bandwidth Allocation, Optical Network, Windows-Based Bandwidth Allocation, Dynamic Bandwidth Allocation

## 1. Introduction

In these years with the increasing popularity of the Internet, the traffic produced by medium and small business users has been growing firmly. Several technologies have been spread out broadband access to the networks. As network operators try hard for cost efficiencies, it seems that Passive Optical Network (PON) to be the next jump in the development of Access Networks (AN). A PON is a point-to-multipoint optical network that there is not any active element in the path between the source and the destination. On the network's side there is an Optical Line Terminator (OLT) unit that is usually placed in the local exchange and it acts as a point of access to the Wide or Metropolitan Area Network (WAN or MAN).

On the customer's side there is an Optical Network Unit (ONU) that can be placed either in the building or home. The primary task of ONU is convert data between optical and electrical domains.

The protocols Asynchronous Transfer Mode (ATM) and Ethernet have been recommended as the transmission protocol in PONs. In these years for this reason that the EPONs are flexible they have gained more attention from the industry. The architecture of an Ethernet network is simple yet highly operative. The ability of work between old and new networks can easily be support and inheritance solutions can be used as EPON data is coming in standard Ethernet frames.

Naturally the EPON networks are accept in a tree topology with multiple ONUs that is linked to a OLT as a splitters. There are two type of transmission that we show in Fig1, Fig2. In a downstream transmission (Fig. 1) the OLT uses all bandwidth to broadcast packets through the splitter to each ONU. Each ONU

---

<sup>+</sup> Corresponding author.  
E-mail address: a\_habibi\_1@hotmail.com

excerpt packets by check the Medium Access Control (MAC) address in packets.

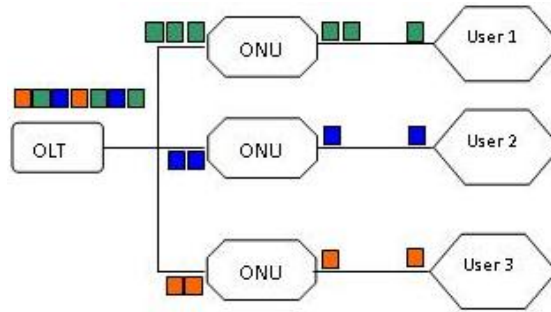

Fig. 1: downstream transmission

In the upstream transmission (Fig. 2) the OLT split the packets as a splitter and send the related packet to ONU and prevent that an ONU reach a packet from other ONUs. So that to escape from collisions that maybe happen between frames from different ONUs the optical splitter must be shared all available bandwidth among all ONUs. The OLT is manager of assigning a non-overlapping time-slot to each ONU, and ONUs can only transfer packets during this time-slot that means in the duration of the off period packets are buffered and when the time-slot come they send packets by using all the available bandwidth.

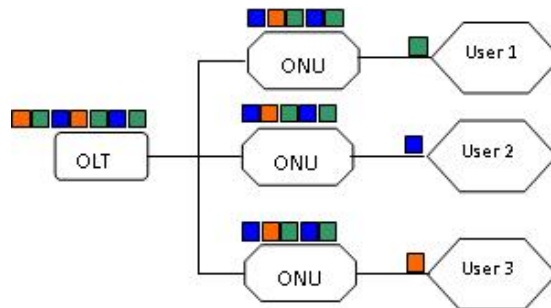

Fig. 2: Upstream transmission

The two main features of EPON networks are that they can support Differentiated Services (DiffServ) architecture and can support various levels of QoS. In a general manner there are three classes of traffic: Expedited Forwarding (EF), Assured Forwarding (AF), and Best Effort (BE). EF services (base for voice and video) have most severe necessity and require a constant low delay and jitter. AF services be given to the less sensitive to packet delay but require an assured amount of bandwidth. BE traffic is generated by applications that have no powerful necessities regarding to traffic properties.

In this paper we examine various Bandwidth Allocation (BA) algorithms and have been done a survey on Router-Based Bandwidth Allocation (RBA). The inspection of major problems, find one of the best solutions and explain the founding techniques were our view point in this survey.

## 2. WBA Weaknesses

1. Window-Based Congestion Control: when you study the existence of fair end-to-end congestion control schemes, more precisely, the question is that of the existence of congestion control protocols that converge to a fair equilibrium without the help of the internal network nodes, or routers. Using such a protocol, end-nodes, or hosts, monitor their connections. By so doing, the hosts get implicit feedback from the network such as round-trip delays and throughput but no explicit signals from the network routers. The hosts implement a window congestion control mechanism. Such end-to-end control schemes do not need any network configuration and therefore could be implemented in the Internet without modifying the existing routers or the IP protocol.

The first problem in this way is: In TCP as a windows-based protocol, congestion control is based on controlling the end-to-end window; an important attribute of TCP congestion control mechanisms is that TCP sources do not have any explicit support for the congestion state from the network. [17]

And the second problem is: The current version of the Transmission Control Protocol (TCP) results in large queuing delays at bottlenecks, and poor quality for real-time applications that share a bottleneck link with TCP.

And the third problem is: In window-based congestion control schemes, increase rules determine how to probe available bandwidth, whereas decrease rules determine how to back off when losses due to congestion are detected. The control rules are parameterized so as to ensure that the resulting protocol is TCP-friendly in terms of the relationship between throughput and loss rate.

2. Utility Fair Congestion Control: there are several algorithms that solve congestion control of communication networks as a distributed algorithm at sources and links in order to solve a global optimization problem. Some applications, especially real-time applications have non-concave bandwidth utility functions. A voice-over-IP flow, for instance, receives no bandwidth utility, if the rate is below the minimum encoding rate. Its bandwidth utility is at maximum, if the rate is above its maximum encoding rate. Then the problem is on the user-received side utility.

3. Bandwidth-delay tradeoff: increasing bandwidth-delay product of high-speed wide-area networks is well-known to make conservative dynamic traffic control schemes. Still, most existing schemes use dynamic control, among which TCP and ATM Forum's rate-based flow control are prominent examples. So far, little has been investigated as to how the existing schemes will scale as bandwidth further increases up to gigabit speed and beyond. The effect of large bandwidth-delay product on dynamic window protocols such as TCP, show the scalability problem. [10]

4. End-to-end Flow Control: the complexity of Internet was brought out by some factors listed below:

- The number of the users and sub-systems are tremendous.
- The diversity of the network services and resources.
- Both users and network nodes can obtain only some limited information.
- The resources of the Internet are limited, and they are owned by many different organizations. So the Internet cannot be managed in central way.
- Distributed systems (such as Internet) are dynamic, cannot be controlled in static way.

Due to these reasons, traditional network control and management mechanisms cannot adapt to new requirements and complexity in the Internet, new mechanisms and analysis tools must be developed.

5. Congestion Control for Future High Bandwidth-Delay Product: as the per-flow product of bandwidth and latency increases, TCP becomes inefficient and prone to instability, regardless of the queuing scheme. This failing becomes increasingly important as the Internet evolves to incorporate very high-bandwidth optical links and more large-delay satellite links. [8]

6. Fair and Efficient in Multi-Application Networks: in today's telecommunication enterprises Multi-application networks are increasingly predominant. The convergence trend towards IP technology has facilitated the deployment of environments where a wide variety of applications, ranging from highly adaptive to strict real-time, coexist and have their traffic transmitted over the same network infrastructure. In this case, as opposed to the homogeneous scenario, the amount of resources required by each type of application to perform well may differ substantially imposing an extra difficulty to the resource allocation problem. The concept of utility function can be used to provide information about the amount of resources needed by each application and also to support the determination of an adequate solution for the bandwidth allocation problem. [3]

7. Expenses and cost: router mechanisms designed to achieve fair bandwidth allocations, such as Fair Queuing, have many desirable properties for congestion control in the Internet. However, such mechanisms usually need to maintain state, manage buffers, and/or perform packet scheduling on a per-flow basis, and this complexity may prevent them from being cost-effectively implemented and widely deployed. [15]

### 3. WBA Improvements:

1. Window-Based Congestion Control: for the first problem an algorithm is proposed which uses the successive binary congestion information provided by ECN. Based on the explicit network information, and estimate the fair window size proportional to the propagation delay.

For second problems a new model is proposed for the dynamic relationship between window sizes, sending rates, and queue sizes. This system is:

- Window sizes as inputs
- Queue sizes as outputs

And is the inner loop at the core of window-based congestion control.

And for the third problem in congestion control they proposed a spectrum of TCP-like window-based congestion controls. Unlike memory less controls such as AIMD and binomial controls, our controls utilize history information. They are TCP-friendly and TCP-compatible under RED queue management.

2. Utility Fair Congestion Control: in this problem after to translate the theoretical framework into practical application a mathematical method is proposed that enabled us to efficiently construct bandwidth utility functions for real-time applications

3. Bandwidth-delay tradeoff: the simplest (but unreal) solution is to eliminate the feedback delay would be to "move" the control point (i.e. congestion control algorithm at the source) to where the control action actually applies (i.e. the congested switch), eliminating the physical distance barrier. But they proposed Bandwidth-Latency Tradeoff (BLT) as a new approach that has 2 steps:

A data stream to the network carries multiple performance parameter values at the same time. To create the parameter space, the source uses the bandwidth otherwise wasted unused, due to the inherent conservativeness of dynamic control methods.

(2) The controller (switch/destination) can then choose an appropriate parameter value that exactly fits the network condition at the time of its control action. Since the source yields the right to exercise the control action to the controller, the control point is effectively "moved" to where the controller is. [10]

4. End-to-end Flow Control: they proposed an evolutionary game based end-to-end flow control algorithm that is TCP alike. In this new flow control algorithm, there are five strategies can be used by each network user, and in the stage game of our model, these strategies will be played when every ACK is received and every timeout is detected.

5. Congestion Control for Future High Bandwidth-Delay Product: for solve this problem they proposed explicit Control Protocol (XCP) that is a novel approach to Internet congestion control that outperforms TCP in conventional environments, and remains efficient, fair, scalable, and stable as the bandwidth-delay product increases. This protocol generalizes the Explicit Congestion Notification proposal (ECN). In addition, XCP introduces the new concept of decoupling utilization control from fairness control. This allows a more flexible and analytically tractable protocol design and opens new avenues for service differentiation. [8]

6. Fair and Efficient in Multi-Application Networks: they propose a dynamic algorithm based on weighted fair queuing (WFQ) to promote fairness and efficiency in the allocation of bandwidth for multi-application networks. [3]

7. Expenses and cost: they proposed CSFQ as a new architecture that approximates the service provided by an island of Fair Queuing router, but has a much lower complexity in the core routers.

The architecture has two key aspects:

- To avoid maintaining per-flow state at each router, we use a distributed algorithm in which only edge routers maintain per-flow state, while core (non edge) routers do not maintain per-flow state but instead utilize the per-flow information carried via a label in each packet's header.

- To avoid per-flow buffering and scheduling, as required by Fair Queuing, we use FIFO queuing with probabilistic dropping on input. [15]

## 4. WBA Findings

- Window sizes are changed in bandwidth domain without the help of feedback information. Conceptually, since the change of window size occurs in the bandwidth domain, the window change occurs at the same instance in time. So the traffic source sends out the whole spectrum of windows at the same time. It takes more bandwidth to create this spectrum of windows, but it can help alleviate the delay problem. [10]
- The bottleneck switch chooses the right window size among the array of window sizes, discarding all others. Since the switch does not need communication with the traffic source to negotiate on the window.[10]
- The cross-traffic does not merely reduce the capacity available for the congestion controlled traffic.[22]
- But the dynamical properties of the congestion control are also affected[22]
- For the inner-loop, increasing the cross-traffic increases the static gain between window size and queue size, and it slows down queue convergence. [22]

## 5. Conclusions

In this paper we address a survey in Windows-Based Bandwidth allocation (WBA) in Dynamic bandwidth allocation group and inspect some problems in this area such as Bandwidth-delay tradeoff, End-to-end Flow Control, Expenses and Price then found the best solution for them in previous researched that has been done. Finally try to explain some theoretical or experimental result as finding items in each section such as cross-traffic which does not merely reduce the capacity available for the congestion controlled traffic.

## 6. Acknowledgment

We would like to express our appreciation to our parents and all the teachers and lecturers who help us to understand the importance of knowledge and show us the best way to gain it.

## 7. References

- [1] AMOTZ BAR-NAY, Y. M. A. B. S. (1998) *Competitive Dynamic Bandwidth Allocation*. PODC 98 Fbxto Vallarta Mexico.
- [2] ANSARI, Y. L. A. N. (2005) Limited sharing with traffic prediction for dynamic bandwidth allocation and QoS provisioning over Ethernet passive optical networks. *JOURNAL OF OPTICAL NETWORKING*.
- [3] BARRIA, R. M. S. A. J. A. (2004) *Fair and Efficient Dynamic Bandwidth Allocation for Multi-Application Networks*. Imperial College London.
- [4] BEN HARDEKOPF, T. R., JAYARAM MUDIGONDA, MICHAEL DAHLIN AND HARRICK VIN (2003) *Impact of Network Protocols on Programmable Router Architectures*.
- [5] BOUTABA, Y. I. A. R. (1999) *A Dynamic Bandwidth Allocation Algorithm for MPEG Video Sources in Wireless Networks*. ACM.
- [6] DAWID NOWAK, P. P. A. J. M. (2004) *Bandwidth Allocation for Service Level Agreement Aware Ethernet Passive Optical Networks*.
- [7] DAWID NOWAK, P. P. A. J. M. (2004) *Bandwidth Scheduling Techniques for Differentiated Services Support in Ethernet Passive Optical Networks*.
- [8] DINA KATABI, M. H. A. C. R. (2003) *Internet Congestion Control for Future High Bandwidth-Delay Product Environments*.
- [9] EVANS, R. P. A. J. B. (2002) *Experiences with Class of Service (CoS) Translations in IP/MPLS Networks*. University of Kansas.
- [10] FARBER, H. K. A. D. J. (1994) *Congestion control by bandwidth-delay tradeoff in very high-speed networks: the case of window-based control*. University of Pennsylvania.

- [11] G. BOGGIA, P. C., L. A. GRIECO AND G. TOMASICCHIO (2007) *A Dynamic Bandwidth Allocation Algorithm for Supporting Real-time Applications in 802.15.3 WPANs*. ACM.
- [12] GUERIN, Y. X. A. R. A. (2005) *On the Robustness of Router-based Denial-of-Service (DoS) Defense Systems*. ACM.
- [13] IBRAHIM KHALIL, B. M. A. A. M. R. M. (1995) *Bandwidth allocation in high speed networks with multiple nested charge class*. IEEE.
- [14] ION STOICA, S. S. A. H. Z. (1999) *Core-Stateless Fair Queueing: Achieving Approximately Fair Bandwidth Allocations in High Speed Networks*.
- [15] J. Li, Y. Jiang, R. Fan. Recognition of Biological Signal Mixed Based on Wavelet Analysis. In: Y. Jiang, et al (eds.). *Proc. of UK-China Sports Engineering Workshop*. Liverpool: World Academic Union (World Academic Press). 2007, pp. 1-8. (Use "References" Style)
- [16] R. Dewri, and N. Chakraborti. Simulating recrystallization through cellular automata and genetic algorithms. *Modelling Simul. Mater. Sci. Eng.* 2005, **13** (3): 173-183.
- [17] A. Gray. *Modern Differential Geometry*. CRE Press, 1998.